

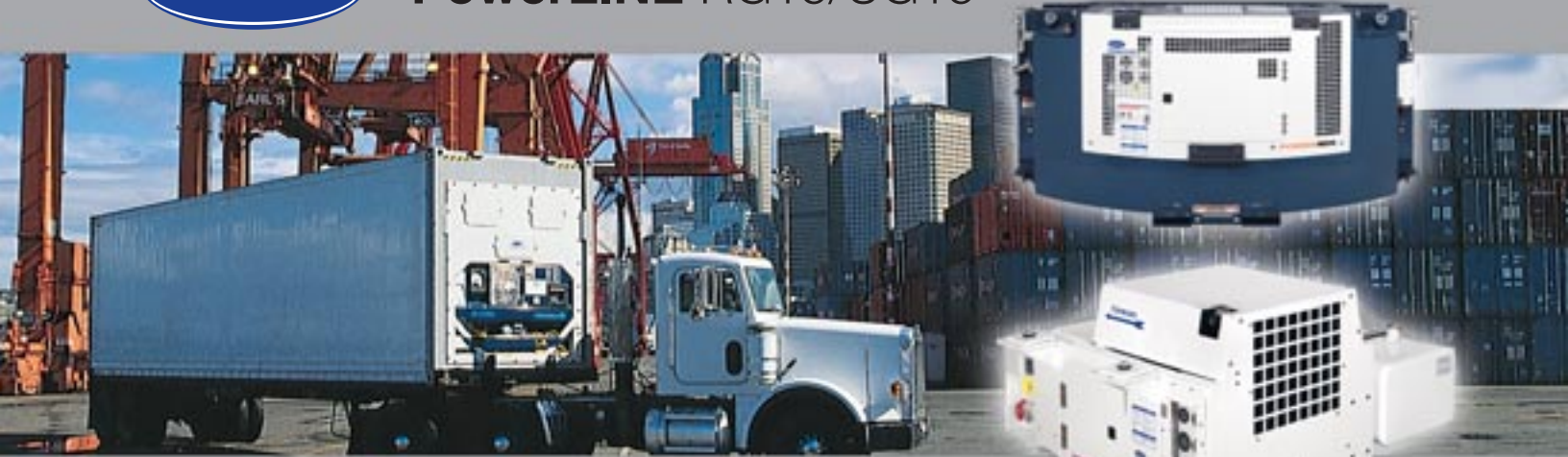

## PowerLINE RG15/UG15



*Rugged construction, dependable power, simple operation.*

# PowerLINE RG/UG

PowerLINE generator sets.  
Simple, reliable power that's easy to get attached to.

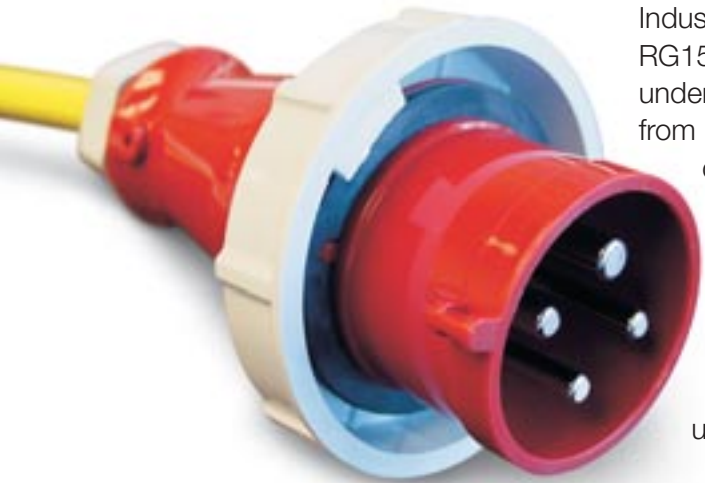

Industry-leading PowerLINE™ RG15 clip and UG15 undermount generator sets from Carrier Transicold are designed and built for one purpose: continuous, unattended operation for all refrigerated containers transported by road or rail, worldwide. Allowing uninterrupted quality.

## **So reliable. So easy to operate and maintain.**

The driving force behind every Carrier PowerLINE generator set is the industry's most reliable power train. Specially engineered to run container refrigeration systems, the Carrier Transicold engine and generator combination delivers uninterrupted power to protect sensitive cargo, even under high inductive loads. You don't have to worry about nuisance shutdowns caused by high-ambient startups and cross-country transport.

## **Our Extended Service Interval reduces costs.**

ESI, our Extended Service Interval feature, standard on all Carrier gen sets, reduces the hassles and added cost of maintenance scheduling and downtime. Recommended maintenance intervals are now extended beyond previous levels for oil, coolant, and filter changes. Regular pretrip inspections are required to maintain fluid levels and ensure system integrity. Overall, ESI reduces your total life-cycle cost.





### Carrier EPA-certified low-emission diesel engine.

Built specially to handle rugged gen set applications, our CT4-DI engine delivers clean, dependable power. One of the most technologically advanced diesel engines available, its superefficient combustion meets all U.S. Government regulations. Unlike some competitive models, the CT4-DI is certified by the U.S. Environmental Protection Agency for gen set operation at 1800 rpm. Direct-injection fuel system provides maximum fuel efficiency and 8%-10% better fuel economy than indirect designs. Industry-high oil sump capacity (16+ liters, 17+ quarts) ensures long drain intervals without compromising engine life. Rated at 25.4 kw (34 horsepower), the CT4-DI delivers ample power to start any reefer anywhere.



CT4-DI diesel engine is EPA-certified.



### A powerful gen set generator.

Our powerful, reliable, low-maintenance PowerLINE generator provides continuous power for uninterrupted protection. Designed for high inductive loads and superior motor-starting capability, our direct-drive brushless generator features an internally excited, self-regulated design. All voltage components are enclosed within the generator package. Wet-wound, thermosetting epoxy is applied to each copper winding turn, eliminating air gaps. Polystator coating offers superior resistance to moisture and salt.



Brushless, self-regulated design produces 460 volts.

### So easy to start.

Fast, sure starting puts your operator in complete control.

- The PowerLINE start/stop switch is mounted low in front, within easy reach.
- Analog instrumentation is easy to read to confirm output.
- Engine glow plugs and electronic fuel heater ensure fast starting and trouble-free operation even at low ambient temperatures.



Control box with easy-to-read gauges.

**SAFE AND SECURE MOUNTING:  
CLIP**



Clamp-style



Header pin

**UNDERMOUNT**



Standard clamp



QuickMount™ bracket

**So easy to operate.**

Unmatched convenience and safety make PowerLINE number one for operating control, with everyone who operates it.

- Up-front analog instrumentation is easy to read and gives you immediate access to key operating parameters.
- The control system is uncomplicated and easy to access and troubleshoot.
- The electrical receptacle is located within easy reach on the front panel. (25-amp main safety switch cuts power when connecting or disconnecting the power cord.)



Safe, easy power cord connection.

**So easy to attach.**

Whether you choose clip or undermount, PowerLINE gives you more mounting flexibility.

- Attaching and disconnecting the gen set takes just minutes.
- If you prefer clip mounting, our pin-mounting bracket design saves time.
- If you prefer clamp mounting, our self-aligning ratcheted clamp locks allow safe, secure attachment to corner castings.
- If you prefer undermount, you can choose standard four-point mounting or our exclusive QuickMount™ design.
- Our four-point mounting system with captive hardware is the easiest standard mounting system to install.
- In operations that require moving gen sets frequently, our optional QuickMount system cuts mounting time in half.
- Hinged mounting brackets and captive hardware enable you to tighten mounting bolts from the side of the frame.
- Secure and durable, these systems stand up to constant shock and vibration.

**So much flexibility, so much control.**

Whether you require clip or undermount power, no one gives you so many gen set mounting options. Or makes it easier to attach or disconnect gen set equipment. Full-range operating flexibility combined with unmatched reliability has made Carrier Transicold the leader in container and intermodal transport refrigeration.

# PowerLINE RG/UG

## Performance, protection, and profitability. They add up to PowerLINE.

PowerLINE clip and undermount generator sets extend product life, maximize cargo capacity, optimize operating efficiency, and provide dependable long-range protection. It's all part of The Complete Package of performance, service, and support that only Carrier offers. For today's business-minded shipping lines, The Complete Package ensures complete protection of valuable cargo. And complete satisfaction for growers and importers alike.



**The key word  
in PowerLINE is power.**

PowerLINE generator sets offer the ideal combination of horsepower, torque, and motor-starting capability. As a result, PowerLINE generates all the power you need to start a wide variety of reefers anywhere. And all the power to keep them running under the toughest conditions.



**PowerLINE keeps it  
simple, keeps it reliable,  
keeps it moving.**

Easy-to-operate Glow-and-Start switches allow quick, easy starts. All instruments on the control panel face – hourmeter, ammeter, pressure gauges – are easy to read. Everyone who touches the panel face finds friendly, easy-to-follow protocols.



**EPA-certified, low-  
emission engine is safer  
for the environment.**

Built to handle rugged gen set applications, our CT4-DI diesel engine delivers clean, dependable power to spare. Its advanced, superefficient combustion meets all U.S. Government regulations. The CT4-DI is EPA-certified for 1,800 rpm operation.



**Our weight savings  
become your  
profit opportunity.**

Ultrastrong, lightweight Carrier SpaceFrame design not only helps protect cargo quality, it also helps increase cargo capacity. Our exclusive welded steel SpaceFrames weigh significantly less than other designs. That gives you the potential to load additional cargo.



**Attachment options  
that hold more than your  
interest.**

To control mounting costs, we offer full flexibility. PowerLINE clip-on models can be specified for pin or clamp mounting. Undermount models offer the choice of standard four-point mounting as well as the time-saving QuickMount feature. Specify either when ordering.



**Lower maintenance costs,  
lower operating costs,  
longer life.**

PowerLINE models feature a larger oil sump and advanced filters and coolant. As a result, we can offer an Extended Service Interval package to further extend maintenance intervals, while offering superior fuel, air, and oil filtration for maximum operating efficiency.



**The preferred choice of  
major shipping lines and  
equipment users alike.**

Experienced people, dependable operation, uninterrupted cargo protection, and worldwide support have made Carrier generator power the first choice of more shipping lines and major gen set equipment users supplying the world market.



**Carrier  
brings you The Complete  
Package.**

Advanced equipment, expert assistance, and global support make Carrier the first choice for uninterrupted quality control all the way from field to market. Carrier people, products, and protection. It's The Complete Package that instills complete confidence.

# PERFORMANCE SPECIFICATIONS

## PowerLINE

### RG15 Clip

Specifications are subject to change without notice.

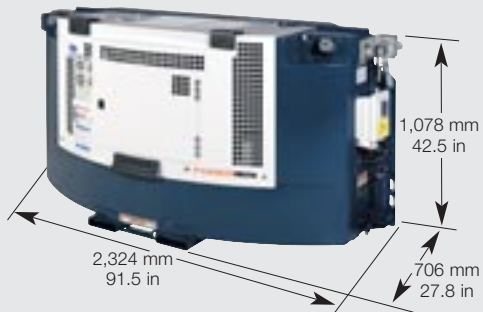

#### Standard Features Include:

CT4-134DI 4-cylinder, water-cooled, 2.2-liter direct-injection diesel engine  
 Nominal 15 kW brushless, self-regulated generator, 460V output  
 130-gallon (492-liter) fuel tank  
 Pin-mount system  
 High-efficiency air cleaner  
 Full-flow spin-on oil filter with internal bypass  
 Integral fuel filter with water separator and electronic fuel warmer  
 Stainless steel hardware  
 Low-mounted controls  
 Large service access door with self-locking/quick-release latch  
 Enclosed forklift pockets  
 12V DC maintenance-free battery  
 Safety stop controls for low oil pressure, high water temperature  
 Patented E-coat tube and fin radiator  
 Large oil pan capacity for 3,000 running hours between oil changes\*  
 Fuel gauge, color-coded for easy level identification from a distance

Oil pressure and water temperature gauges  
 DC ammeter  
 Shipping bumpers  
 Power output circuit breaker  
 Preheat and Start/Run/Off switches  
 Engine hourmeter  
 Solid-state battery charger  
 Operating instruction labels (English and Spanish)  
 Maintenance and schematic labels  
 460V receptacle with spring-loaded cap

\*With Carrier ESI oil filter

#### Accessories and Options:

Auto Restart  
 Clamp-mount system or provision for clamp mount  
 102-gallon (386-liter) fuel tank  
 CE certification

#### Approximate Weight:

814 kg (1,795 lb.) less fuel

### UG15 Undermount

Specifications are subject to change without notice.

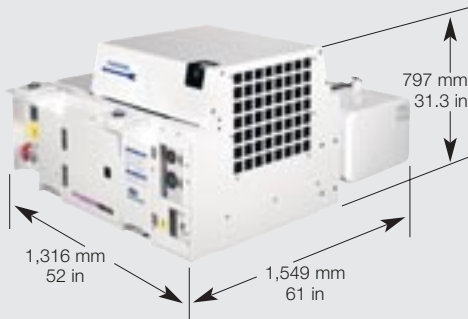

Fuel tank lengths:  
 50 gal (189 L) = 1,143 mm 45.0 in  
 68 gal (257.5 L) = 1,485 mm 58.5 in  
 80 gal (303 L) = 1,632 mm 64.3 in

#### Standard Features Include:

CT4-134DI 4-cylinder, water-cooled, 2.2-liter direct-injection diesel engine  
 Nominal 15 kW brushless, self-regulated generator, 460V output  
 All-steel fabricated frame construction with four-point PlateMount system  
 High-efficiency air cleaner  
 Full-flow spin-on oil filter with internal bypass  
 Integral fuel filter with water separator and electronic fuel warmer  
 Stainless steel exhaust  
 Stainless steel hinges and hardware  
 Driver-side controls  
 Large aluminum service access door with quick-release latch  
 12V DC maintenance-free battery  
 Safety stop controls for low oil pressure, high water temperature  
 Patented E-coat tube and fin radiator  
 Large oil pan capacity for 2,000 running hours between oil changes\*  
 Fuel gauge, color-coded for easy level identification from a distance  
 DC ammeter  
 Power output circuit breaker  
 Preheat and Start/Run/Off switches

Coolant overflow bottle  
 Engine hourmeter  
 50-gallon (189-liter) integral fuel tank  
 Operating instruction labels (English and Spanish)  
 Maintenance and schematic labels  
 Oil pressure and water temperature gauges  
 Solid-state battery charger

\* With Carrier ESI oil filter

#### Accessories and Options:

Four-point QuickMount installation system (w/single captive bolts)  
 Auto Restart  
 68-gallon (257-liter) integral fuel tank  
 80-gallon (303-liter) integral fuel tank  
 110-gallon (416-liter) remote fuel tank

#### Approximate Weights:

712 kg (1,570 lb.) with 50-gallon (189-liter) integral fuel tank  
 719 kg (1,585 lb.) with 68-gallon (257-liter) integral fuel tank  
 685 kg (1,510 lb.) with 80-gallon (303-liter) integral fuel tank

#### Warranty:

Within two years after the date of shipment from the manufacturer's plant or 27 months from the manufactured date, whichever comes first, Carrier Transicold Division, through designated Container Service Centers, will, at Carrier Transicold's option, repair or replace, with a new or remanufactured part, any parts or components of the products identified above which UNDER NORMAL USE AND SERVICE malfunction as a result of defects in material or workmanship. The warranty terms and limitations are listed in Form 62-10185. Consult your Carrier Transicold representative for complete warranty details.

**North and South America**  
 Carrier Transicold  
 Container Products Group  
 1095 Cranbury South  
 River Road, Suite 23  
 Jamesburg, NJ 08831 USA  
 Tel: +1-973-895-1353  
 Fax: +1-973-895-1356

**Europe/Middle East/  
Africa**  
 Carrier Transicold  
 Limited  
 Pittsburgstraat 21  
 3047 BL Rotterdam  
 The Netherlands  
 Tel: +31-10-2380100  
 Fax: +31-10-2380142

**Asia/Pacific**  
 Carrier Transicold  
 Pte. Ltd.  
 251 Jalan Ahmad  
 Ibrahim  
 Singapore 629146  
 Tel: +65-6213-6388  
 Fax: +65-6862-5309

**Asia/Pacific**  
 Carrier Refrigeration  
 (Hong Kong) Ltd.  
 Unit A-C, 20/F  
 Tsuen Wan  
 International Centre  
 68 Wang Lung Street  
 Tsuen Wan, N.T.  
 Hong Kong  
 Tel: +852-288-00389  
 Fax: +852-288-00314

**Japan**  
 Toshiba Carrier  
 Transicold, Ltd.  
 14 Nihon Odori  
 Naka-Ku, Yokohama,  
 Japan  
 Tel: +81-45-664-6271  
 Fax: +81-45-664-6270

**Australia**  
 Carrier Refrigeration  
 Building A, Lot 302  
 Hill Road, Lidcombe  
 Sydney, NSW 2141  
 Australia  
 Tel: +61-2-9818-9700  
 Fax: +61-2-9810-4139



**Carrier**

A United Technologies Company

Carrier Transicold Division  
 Carrier Corporation  
 Container Products Group  
 P.O. Box 4805  
 Syracuse, NY 13221 USA

www.container.carrier.com

