



IT'S EVERYTHING YOU NEED IN AN ARMORED CAR EVAPORATOR TODAY.

Our Excel EM22 air conditioning evaporator has been engineered for maximum serviceability and ease of installation in armored vehicles.

SPECIFICATIONS

Standard Features Include:

- Our Patented Quick Click™ refrigerant hose and fitting system is a standard feature on the EM22. Heavy-duty construction. Heavy-duty galvanized steel frame is reinforced for added strength. Epoxy Powder Coated for Added Durability.
- Positive drain system. High-Capacity drain pan, baffled to provide positive condensate removal-without splashing.
- High-volume airflow, widely dispersed for total passenger comfort.
- Quiet, multi-speed, high-efficiency blowers engineered for minimum current demand.
- O-ring connection on expansion valves eliminates costly refrigerant leaks and simplifies service.
- Adjustable Air Directional Louvers.
- Provides more headroom clearance than any comparable unit.
- Filter: Durable aluminum mesh.

Cooling Capacity: 25,000 BTU/HR (6300 KCAL/HR)

Heating Capacity: 30,000 BTU/HR (7560 KCAL/HR)

Cooling coil: Three rows deep, copper tubes expanded into aluminum fins.

Heating coil: Two rows deep, copper tubes expanded into aluminum fins.

Evaporator blower:

High Speed - 525 CFM (892 M/HR)

Med. Speed - 360 CFM (612 M/HR)

Low Speed - 290 CFM (493 M/HR)

Expansion valve: Block type with O-ring connection and multi-outlet venturi-type distributor.

Evaporator motor: Multi-speed, permanently lubricated ball bearings. Engineered for continuous duty. Current draw @13.5 VDC

High - 20

Med. - 11

Low - 6



TRANSPORT AIR CONDITIONING

The EM22 evaporator can be matched with other Carrier Transicold components to provide a complete air conditioning system that meets your exact vehicle size, operating mode, and climate.

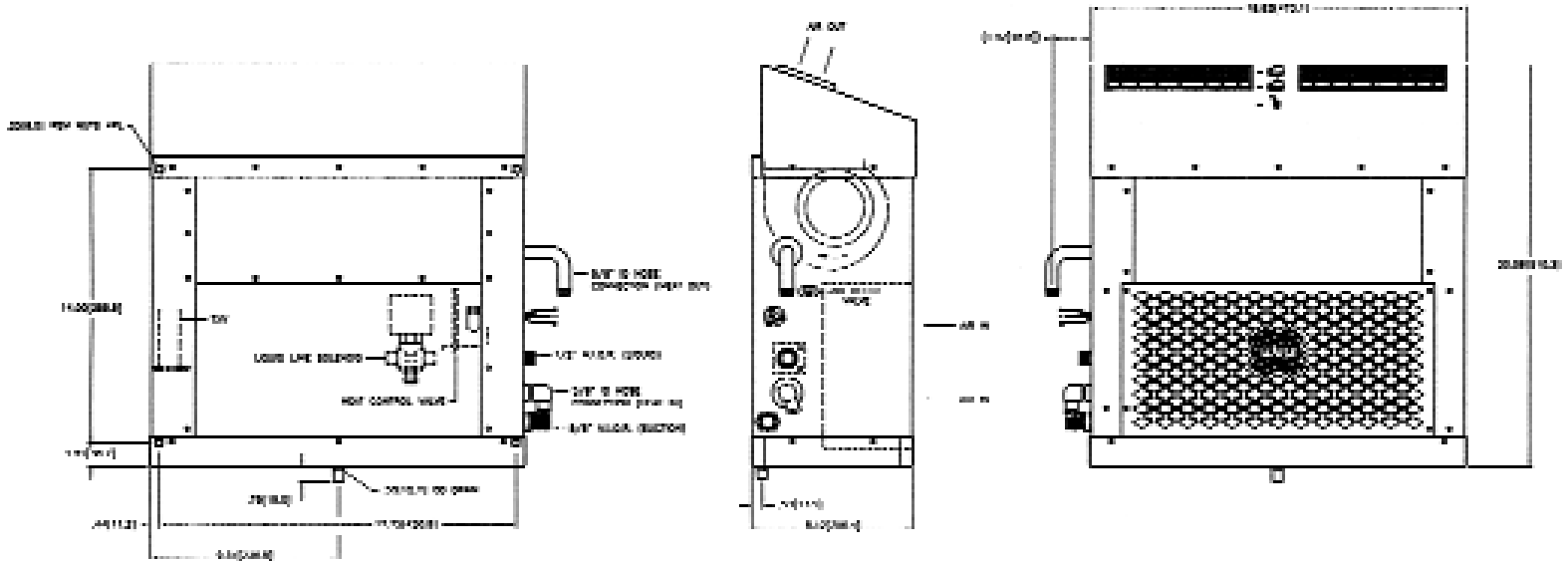

WEIGHT: 40 lb. (18.12 kg)

WARRANTY: Carrier Transicold split systems are covered by an industry-leading two-year warranty. Complete terms and limitations are outlined in Form 62-02737. Consult your Carrier Transicold representative.

OPTIONS: 12v or 24v operation

Specifications are subject to change without notice.



TRANSPORT AIR CONDITIONING

715 Willow Springs Lane
 York, PA 17402
 717-767-6531
 800-673-2431
 Fax: 717-764-0401

WE VALUE YOUR BUSINESS.™

Printed in USA 0898
 Form 62-02809-01
 ©1999 Carrier Transport Air Conditioning

